

MAGNET FREE ELECTRIC MOTOR SOLUTION

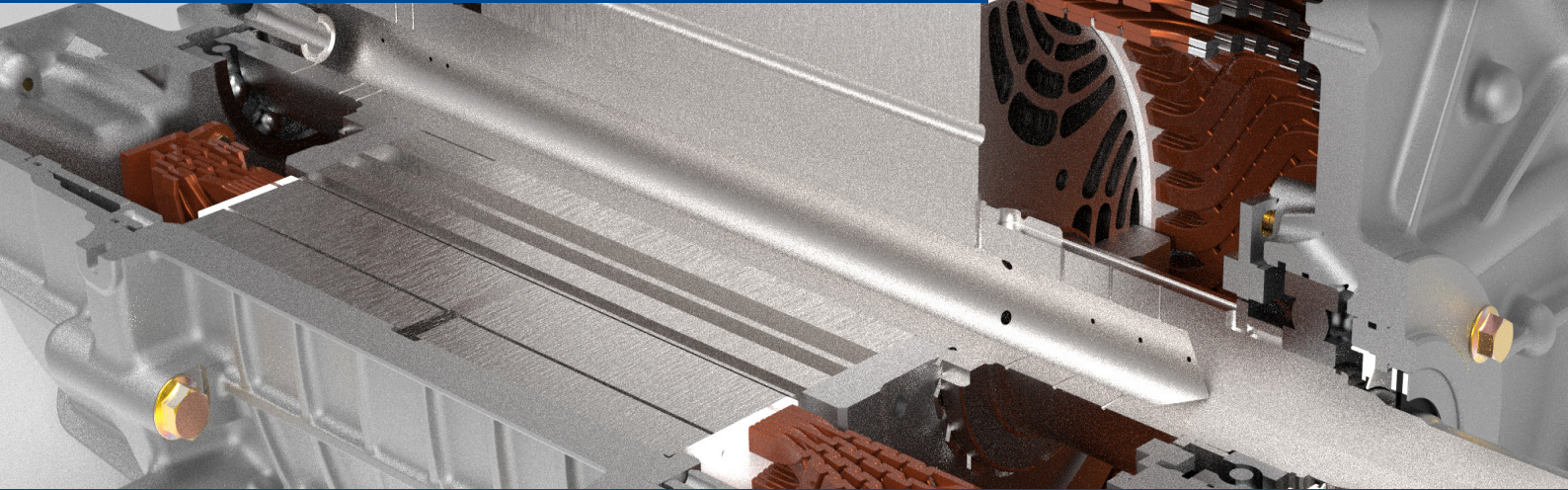

Robust, low cost and highly sustainable - the ALUMOTOR solution is perfect for light commercial vehicle and off-highway applications

ALUMOTOR is a rare-earth free electric motor solution designed for applications where supply chain security and robustness are critical.

The aluminium-wound design is permanent magnet free and low copper, enabling a more robust and sustainable supply chain and removing up to 60% of the cost of a standard electric motor.

It includes hairpin winding configuration and innovative cooling technology, enabling increased operating efficiency whilst keeping costs low.

ALUMOTOR is best suited to light commercial vehicle, off-highway and specialised vehicle applications requiring a robust, low-cost and more sustainable solution for their electric vehicle portfolios.

KEY BENEFITS

- Runs on standard power electronics at 800V
- Robust design
- Low cost
- More sustainable materials
- Designed with supply chain security in mind
- Scalable to a variety of applications

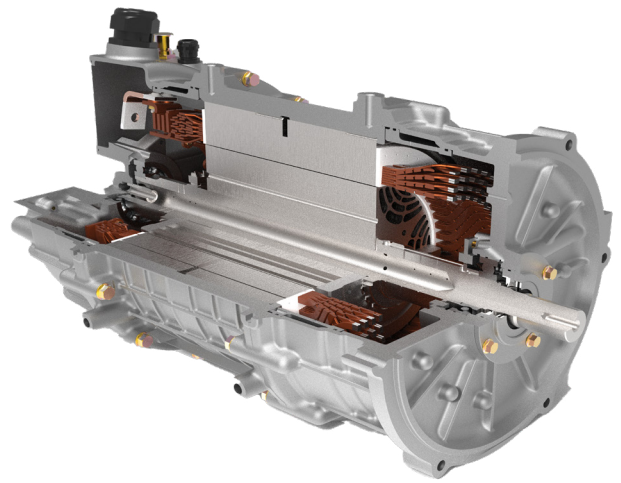

RATED TORQUE	160 Nm
SPEED	7500 RPM
PEAK SPEED	14,000 RPM
PEAK POWER	195 kW
RATED POWER	120 kW
POWER DENSITY	2 kW/kg
COOLING	OIL COOLED WITHIN STATOR AND ROTOR AS WELL AS SPRAY JETS
WEIGHT	80 kg

FIND OUT MORE ABOUT ALUMOTOR

+44 (0)1273 455611 | INFO@RICARDO.COM | WWW.RICARDO.COM/ALUMOTOR